



VINYL SPC FLOORING

INSTALLATION GUIDELINES



SPC laminate floor with underlayment. Pavimento SPC com tela em ixpe.

01

Preparation

The surface of the floor must be clean, dry and stable. Any polish, dirt, paint, etc. must be removed from the job surface. The floor surface must be flat and leveled with a scraped and putty knife. Maintain the room temperature above 15°C before installation. Check that the doors can still open and close after the floor has been installed (minimum +1 cm).

02

Installation

Ensure that all installing product must be the same lot numbers. Position the plank to be installed at an angle of 15° to 20° to the plank already installed. Move the plank gently up and down and the same time exert forward pressure. The planks will automatically click into place. You can either insert the tongue into the groove, or the groove into the tongue. The tongue in groove method is the most common and the easiest way. Please, refer to the installation diagrams for more details.

03

Condition

Existing floor surface level must be within acceptable level with a tolerance level of 1mm only. Otherwise, this will cause high low between SPC planks and waviness effect after completion. It is advisable to do self-leveling cement before lay vinyl planks to avoid waviness effect after completion.

04

Special conditions

- Furniture should be moved onto the newly installed floor using an appliance hand truck over hardboard runways.
- Heavy furniture should be equipped with suitable non-staining, wide-bearing casters, or protectors. Non-staining felt protectors are recommended for table and chair legs to help prevent scratching.
- Close your curtains or blinds where extreme sunlight hits the floor. Like with all floor coverings, protect the finished. Installation from exposure to direct sunlight. A combination of heat and sunlight can cause fading, discoloration, or thermal expansion in most home furnishings. Avoid exposure to direct sunlight for prolonged periods. During peak sunlight hours, the use of blinds or drapes is recommended. Prolonged direct sunlight can result in discoloration and excessive temperatures may cause floor expansion, which may cause buckling or delamination.

- Oil or petroleum-based products can result in surface staining. Do not track asphalt-driveway sealer or automobile-oil drips onto the vinyl floor covering.
- Use mats labeled "non-staining."
- If extreme direct sunlight over 140 degree temperature is a concern.

05

Waterproof warranty

This warranty covers topical moisture as long as the water does not flow over the edge of the surface (edge of the room, cut boards, etc.). Ribadao warrants that for the lifetime of stated warranty period from the date of original purchase, your Ribadao product will not swell, cup or crack due to:

1. Normal cleaning practices (see care and maintenance document for additional information)
2. Moisture due to everyday household spills (see care and maintenance document for additional information)
3. Normal moisture levels from subfloor when exposed to such conditions (see installation instructions document for additional information)
4. While moisture will not affect the product's integrity, it is possible that, when excessive moisture accumulates in buildings, subfloors, or on building materials, mold (and/or) mildew growth can occur - particularly if the moisture problem remains undiscovered or unaddressed. In addition, such excessive moisture levels can cause the ends and/or sides of the product to lift/flare due to the vapor pressure from underneath. Such damage from excessive moisture levels (as outlined in the installation instructions document) are not covered by this warranty. All sources of subfloor moisture should be remedied prior to installation.
5. For jobsite and floor preparation conditions, see product specific installation guidelines. Any moisture related testing (i.e. relative humidity, pH, and calcium chloride) is the responsibility of the installer.
6. Your warranty does not cover the following: damage caused by improper installation and/or maintenance; differences in color between products and samples or photographs; problems arising from excessive moisture, alkali or water pressure from the subfloor; indentation from improper loading including heavy static loads, spiked shoes such as high heels without rubber heel tips, cleats or skates that cause gauging rolling loads, broken chairs or furniture that results in scratching, gouging; discoloration, including but not limited to U.V. light and heat sources; gouging from exclusions listed above, changes in shading, texture and/or gloss during use; damage caused by chemically reactive material, dye, mold, stains, spillage, burns, gouges, scratching, indentations, floods, accidents, abuse or any harsh scouring pads while buffing; and/or damage due to thermal heat sources.

7. This warranty excludes all casualty events involving water coming in contact with your floor and failures normally covered by homeowners' insurance including, but not limited to, damages caused by flooding or standing water from leaky pipes, faucets, or household appliances. Also excluded are damages caused by flooding or standing water from hydrostatic pressure or other casualty events.
8. SPC flooring is waterproof and reliably secures the flooring panels on all four sides. However, excessive moisture in the subfloor could promote mold, mildew, and other moisture related issues like the trapping of moisture emissions under the flooring, which may contribute to an unhealthy indoor environment.
9. Additional layer of Ribadao's 6mil poly film or equal vapor retarder with a perm rating of .1 or less is mandatory to be used as an additional layer of protection, otherwise the warranty is voided.

06

Pet proof warranty

1. The Company warrants that your luxury vinyl floor will resist staining caused by pet (domestic cat or dog) stains, including urine, feces, and vomit. Stain resistance means the ability of your floor to resist (i.e., minimize or withstand) permanent stains for as long as you own your floor. Cleaning of the affected area should begin immediately upon discovery. The more time that elapses before removal, the more difficult a stain will be to remove.
2. The Limited Pet proof Warranty DOES NOT COVER: Any urine, feces, or vomit stains other than pet.

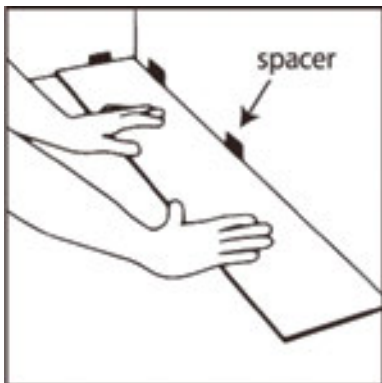

1. Start at a corner. Place first plank with tongue side facing wall. Use spacers to maintain an expansion space of 10-15 mm between wall and flooring.

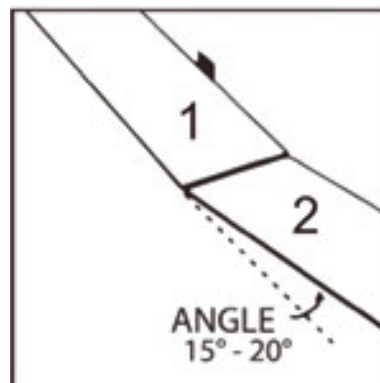

2. Insert 2nd plank's end tongue to 1st plank's end groove at an angle of 15-20 degree. the plank will into place when lowered. Line up edges carefully. Planks should be flat to the floor.

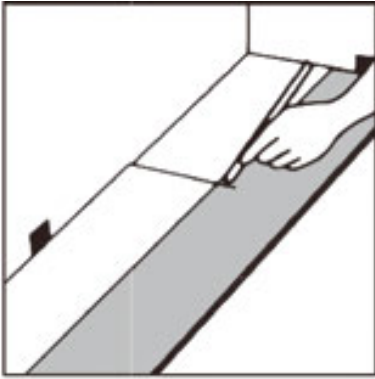

3. For the last plank of a row, flip a full plank to its under side and place beside the row. Measure and mark the required length. Use ruler and utility knife to score the plank and snap off. Insert as previous diagram.

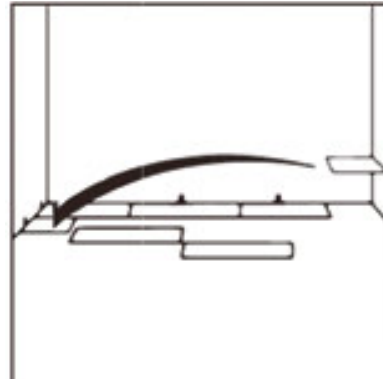

4. Begin next row with the last cut off piece from the previous row to stager the pattern. First plank min length 500 mm. Put a spacer against the left wall.

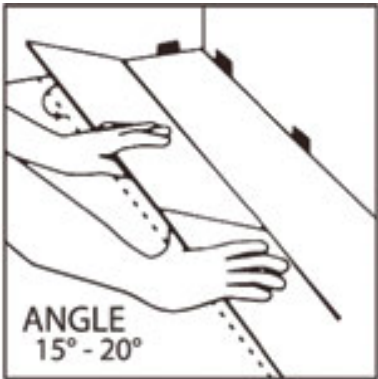

5. To start second row, assemble your entire row on the subfloor before attaching in to the first row. To attach, tilt and push the side tongue into the side groove of the first row at an angle of 15 degrees to 20 degrees. Lower and click into place lining the edges up carefully. Continue laying remaining planks in this matter.

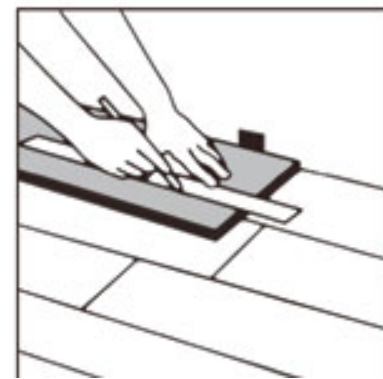

6. To fit the final row, lay a plank upside down on the flooring as per diagram with the tongue side close to the wall. Take another plank and place it right on top of the previous row and use it as a ruler. Don't forget to allow room for spacers. Cut the plank and attach into position.

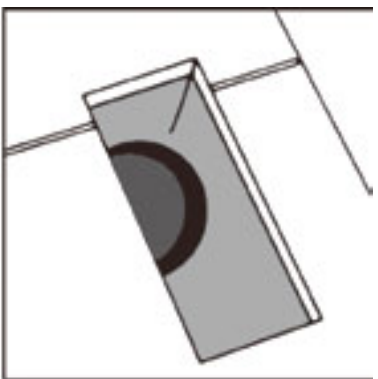

7. Heating vents require expansion room. First, cut plank to the correct length. Place the cut plank at its actual position and use a ruler to measure the areas to be cut out and mark them. Cut out the marked points allowing the necessary expansion distance.



8. The gap between the bottom of a door and the flooring should be 1 cm height. To trim door frames, turn a plank upside down. Place it next to the door frame as per diagram. Use a handsaw and cut away the necessary height so that the planks fit.



RIBADAO

WOOD BOUTIQUE

connect with us!



leave us a review!

15701 NW 15th Avenue Miami, FL 33169 - U.S.A

Phone: +1 888.505.2827

Email: purchasing@ribadao.com

For more information
visit our website

www.ribadaoamericas.com